

Application: Waste sorting-Food Waste bin

The 90L BOOGY mobile pedal bin is ideal for the food industry

Characteristics:

- Virgin high density polyethylene plastic
- Stainless steel rod AISI 304 (18/10) linking pedal to the lid
- Large front pedal
- Handle for easy handling
- HACCP compliant
- Ideal solution for selective sorting

Dimensions:

Without packaging :

Weight : 5,901 kg
 Volume : 0,256 m3
 Dim. (L*I*H) : 0x0x0 mm

With packaging :

Weight : 7 kg
 Volume : 0,256 m3
 Dim. (L*I*H) : 895x520x550 mm

Custom Code : 39249000

Gencod: 3019920563578

Advantages :

- Easy to clean
- Mechanical and corrosion resistance
- Ease of handling / HACCP compliant
- Ergonomic

Palettisation:

Quantity	6
Height (in m)	1,8
Number of items /layer	2
Number of layers / pallet	3
Pallet size (in mm)	1200x1000
Weight (in kg)	55,85

Colours : Grey / Blue

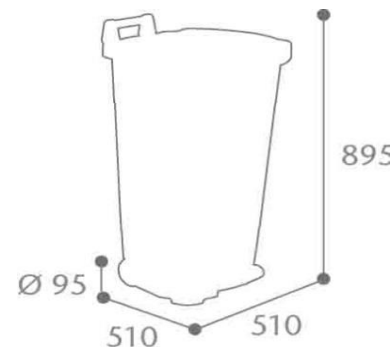

Produit contribuant à la Collecte Sélective des déchets

